

PROJECT NAME BL072 -CHEMISTRY ADDITION – REPLACE AHU-1 THROUGH 4 – PHASE 2
IU PROJECT NO. 20250507 | CREATIVE ENGINEERING PROJECT NO. 2025-035.AH2
ADDENDUM NO. 3
DATE: 4/21/2026

This Addendum consists of two (2) Addendum pages and two (2) attachment pages totaling four (4) pages. This Addendum shall supplement, amend, and become part of the Bid Documents. All Bids shall be based on these modifications. Bidders shall acknowledge the receipt of this addendum on their Bid Form.

GENERAL

PART 1 - AVAILABLE PROJECT INFORMATION

- 1.1 A dumpster will be permitted per the attached site plan (shown as a white rectangle) for the heavy demolition period, roughly from September 1 until December 31, 2026 – *Attachment A* (Site Photo). Successful bidder will coordinate exact dumpster sizing and placement with Construction Manager and Building Manager. 6 FOOT temporary chain link fence and Pantone 201 privacy screen (per IU standard) - *Attachment B* - shall be provided around dumpster, and locked when not in use.

PART 2 - QUESTIONS AND ANSWERS

The following are questions submitted and answers provided. The questions and answers are to be considered as part of the Invitation to Bid.

Question Number	Question	Response
1	Will shutdowns for tie-ins be required after normal business hours?	The owner will work with the successful bidder to minimize requirements for after hours work. Bidders should plan for after hours tie-ins for less than half of the required shutdowns.
2	The install of the temp end caps (note 12) on drawing MD101 connects to hazardous material that is being demoed by others. Will the installing contractor need to be in the "tented area" where the demo is being done? If so, what will need to be worn to be able to do the work. Will this work need to be completed during a shutdown after hours?	No. The installing contractor shall provide the temporary end caps to the abatement contractor and the abatement contractor shall secure the caps in place. The installing contractor shall apply mastic once the abatement contractor finishes and removes tenting.

SPECIFICATIONS

ITEM NO. 1 Specification Section 237313.19 "INDOOR, FIELD BUILT CUSTOM AIR-HANDLING UNITS"

A. Revise paragraph 2.F.6.a to read as follows:

"a. Mount fan, motor and drive on a concrete-filled inertia base with vibration isolators. Concrete by unit manufacturer."

ATTACHMENTS

Exhibit A – Dumpster Location

Exhibit B – Temporary Fence Requirements

END OF ADDENDUM NO. 3



Exhibit A

FRONT

INDIANA UNIVERSITY CAPITAL PROJECTS CONSTRUCTION FENCING SCREEN STYLE GUIDE 05/04/2020

CRITERIA:

- ≥ \$2M AWARDED CONSTRUCTION COST AS A DONOR SUPPORTED PROJECT: USE LETTERED FENCING WITH "PHILANTHROPY AT WORK".
- ≥ \$2M AWARDED CONSTRUCTION COST AS A NON-DONOR SUPPORTED PROJECT: USE LETTERED FENCING
- < \$2M AWARDED CONSTRUCTION COST PROJECT: ONLY SOLID RED (#201) FENCING (NO LETTERING OR LOGOS).

NOTES:

1. ALL LETTERING & LOGO TO BE CENTERED VERTICALLY ON SCREEN FABRIC
2. PROVIDE HALF MOON VENTS 4' O.C. - MIN TWO ROWS VERTICALLY ABOVE AND BELOW LETTERING
3. SCREEN TO BE MINIMUM 80% PRIVACY, KNITTED HDPE UV POLYETHYLENE OR PVC CONSTRUCTION
4. FONTS AND IU LOGO MUST BE PER IU BRAND GUIDELINES/STANDARDS

TEXT
HEIGHT = 24"
FONT = BENTON SANS COMP MEDIUM
COLOR = WHITE
PROJECT NAME (TO BE PER IU CAPITAL PROJECTS)

IU TRIDENT LOGO
HEIGHT = 52"
COLORS:
TRIDENT = WHITE

"PHILANTHROPY AT WORK" IF APPLICABLE (SEE CRITERIA)
WILL IMMEDIATELY FOLLOW THE IU LOGO,
WHICH FOLLOWS PROJECT NAME

SCREEN : SOLID
COLOR = PANTONE 201

MOUNT EVEN WITH TOP
OF CHAIN LINK FENCE

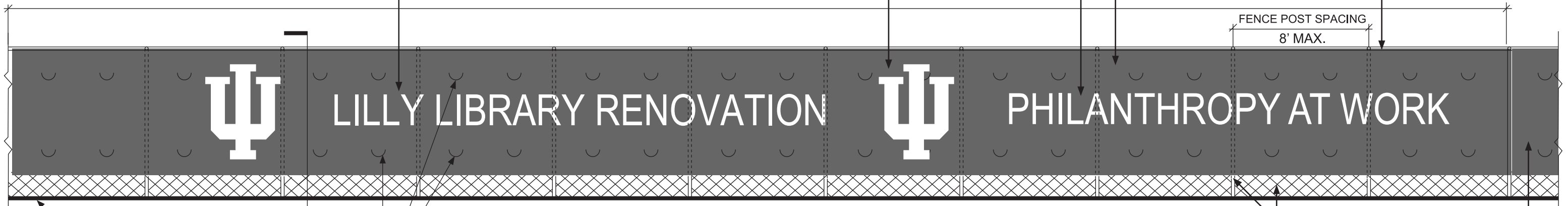

FENCE POST SPACING
8' MAX.

SECTION

LETTERED SCREEN : EXAMPLE SHOWN IS 65' LONG
(PROVIDE AT LOCATIONS AROUND PROJECT SITE AS DIRECTED BY IU CAPITAL PROJECTS)
SCREEN LENGTH IS PROJECT NAME DEPENDENT,
VERIFY W/ CAPITAL PROJECTS' TEAM LEADER

CHAIN LINK FENCING
(SEE SPEC STANDARDS)

SOLID RED (#201) TO
BE AROUND ENTIRE
PERIMETER WHERE
LETTERED PORTION
DOES NOT OCCUR

SECTION

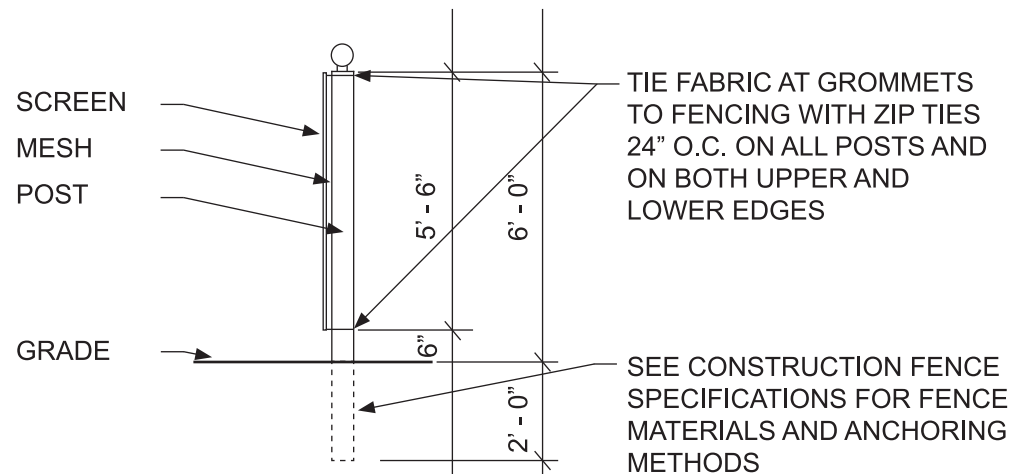

CONTACT INFORMATION

PLEASE CONTACT IU STUDIOS FOR ANY BRAND, LOGO, FONT OR COLOR
NEEDS: studios@iu.edu OR VISIT brand.iu.edu FOR DOWNLOADS

PLEASE CONTACT IU SIGN SHOP FOR ANY ADDITIONAL
CONSTRUCTION NEEDS: 812-856-0761